



OL4

SOLAR WARNING LIGHT

The OL4 is a high-performance light designed to perform reliably at tough industrial locations including rail yards, construction zones, mining operations and more. Suitable for permanent, temporary or emergency installations, the OL4 is unrivalled by any other hazard marking or barricade light currently available.

- Dusk to dawn operation
- Lightweight, self-contained
- Sophisticated solar energy management
- Intuitive on-board user interface
- Intelligent deployment settings for reliable performance in a wide-range of locations
- Proven technology platform

Easy installation and relocation

Lights are immediately operational following a simple installation process. No specialized work crews required.

Self-contained and low-maintenance

All components are safely encased in a durable, rugged enclosure. The OL4 includes a replaceable battery pack that extends the total cost of ownership beyond five years and offers significant cost savings.

Intelligent deployment settings

The OL4 has the unique ability to be tuned to its precise installation location, protecting it against improper configuration.

Unprecedented reliability

Microprocessor Energy Management System (EMS) monitors and adapts to environmental conditions for consistent operation and long life under the toughest conditions.

Designed and tested to tough industrial standards

MIL-STD-202G: Humidity, Immersion, Vibration, Shock; MIL-STD-810G: Solar Radiation, Salt-Fog; EN 60945: ESD, EMI, EMC; IP68; L70. The OL4 is acceptable for barricade and construction applications at Commercial Part 139 Airports under FAA Advisory Circular AC 150/5370-2E. The OL4 Blue is compliant with the requirements of ICAO Annex 14, Volume 1, Fourth Edition dated July 2004.

User-friendly design

On-board user interface, optional infrared remote and USB device manager software offer easy configuration and programming.

Green solution

Recyclable batteries and a RoHS compliant design combined with natural solar charging ensure the lightest environmental footprint.



REPRESENTED IN YOUR REGION BY:



OPTIONAL INFRARED PROGRAMMER

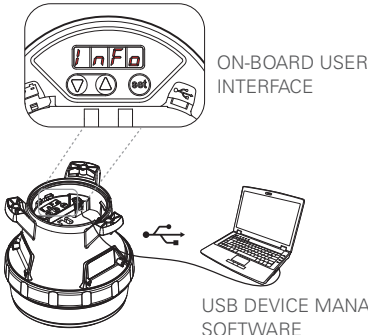

ON-BOARD USER INTERFACE
USB DEVICE MANAGER SOFTWARE

OL4

SOLAR WARNING LIGHT

SPECIFICATIONS

Solar Panel	High-efficiency cells with bypass and blocking diode function. Maximum power point tracking (MPPT) for optimal energy collection
Battery	Tool-less replaceable and recyclable best-in-class battery pack with extreme temperature range. Battery status feedback of Good, Charge or Bad (Replace)
Light Source	High power LED, colour-specific temperature corrected LED drivers provide consistent intensity under all operating conditions
Intensity	4 cd peak (red), steady-on (see photometric plot) 18 cd peak intensity, flashing, 12.5% duty cycle (Red LEDs)
Flash Patterns	256+
Construction	Premium grade UV resistant, polycarbonate/polysiloxane co-polymer body and lens material. Double O-ring sealing with waterproof vent
Colours	Red, blue, yellow, green, white ICAO and SAE25050 (FAA) compliant chromaticity
Colour Indicator	Yes, FAA Eng. Brief 67 compliant
Temperature	-45 to 124 °F (-43 to 51 °C) operating -45 to 176 °F (-43 to 80 °C) storage
Weight	3.5 lbs (1.58 kg)
Wind Loading	400 mph (180 m/s)
Automatic Light Control (ALC)	When enabled, ALC will dynamically reduce brightness in response to unusually low amounts of sunlight to ensure continued operation.

ORDER OPTIONS

MODEL ▼	OUTPUT ▼	SWITCH ▼	CONTROL ▼
OL4	RED BLUE GREEN WHITE YELLOW	SWITCHED NON-SWITCHED	NONE GPS

ACCESSORY ORDERING CODES

Additional Bird Deterrent (1 ships with each light)	57003
Bottom Cover Replacement Kit	57392 (With Switch) 57393 (Without Switch)
Battery Replacement Pack	72835
Battery Charger (includes multiple ends for int'l use)	59188 (100 - 240 VAC)
USB Cable	57394
Device Manager Software	Contact Customer Support
Infrared Programmer	69899
Magnetic Mounting Kit (3 x magnets and hardware)	76296

Additional accessories and mounting options available. For a complete list consult our accessories specification sheet.



The management system governing the manufacture of this product is ISO 9001:2008 certified.

Specifications subject to local environmental conditions.
Specifications may be subject to change.

US and International patents apply. "Carmanah" and Carmanah logo are trademarks of Carmanah Technologies Corp.

PHOTOMETRICS

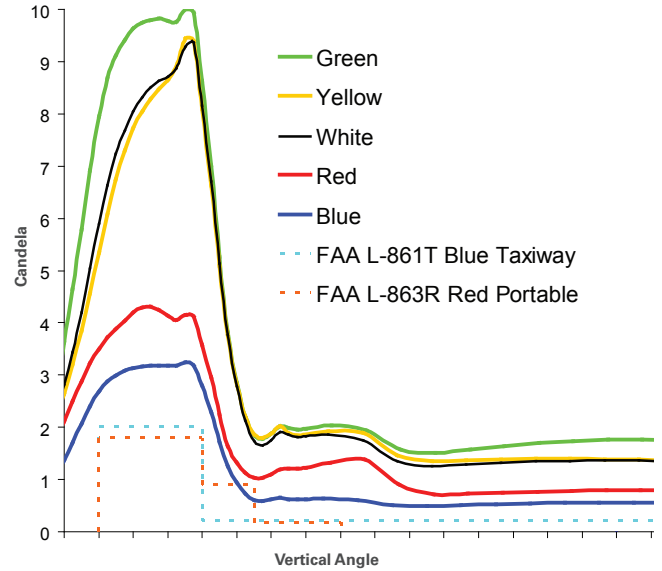

TECHNICAL DRAWINGS AND DIMENSIONS

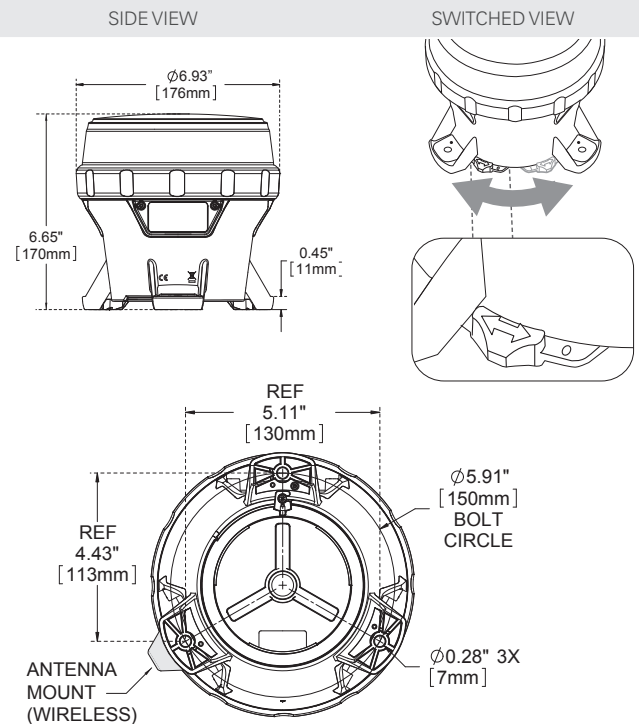

Carmanah is a Canadian public corporation - TSX:CMH
© 2015, Carmanah Technologies Corp.
Document:OL4_Spec_Sheet_RevE