

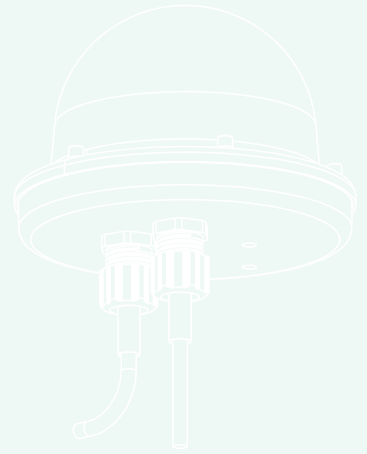

Vega *guides the way*



VEGAWEB MONITORING SYSTEM

MINI VEGAWEB & LARGE VEGAWEB



Mini VegaWeb



Large VegaWeb



Current Transducer



ISO 9001

BUREAU VERITAS
Certification



VEGAWEB MONITORING SYSTEM

VegaWeb is plug and play

VegaWeb is designed to provide a monitoring solution for Aids to Navigation equipment. This is achieved by avoiding customer based equipment and the need for a high level of expertise to be able to operate the monitoring system. System access is achieved using an Internet Browser similar to how Internet banking is provided. Communication uses direct Internet communication over a cellular network and where cellular coverage is not available there is an option using the Orbcom Satellite network.

No system setup costs

By avoiding the need for purchasing computers to host the system and communication networks, VegaWeb monitoring is economical even if only one beacon or light is being monitored.

Automated alarming

VegaWeb does not require full time access to determine if a problem has occurred. Automatic alarming will deliver messages by SMS or email to designated recipients.

Access from anywhere

VegaWeb can be accessed using a computer or mobile WAP phone from anywhere provided that there is internet access. This allows access from the office, from home or even on a business trip.

Generic monitoring system

VegaWeb is designed to work with Vega equipment and Aids to Navigation lights from other manufacturers.

Two forms of outstation

VegaWeb has two forms of outstation, the standard or large unit is designed primarily for monitoring devices that need a higher amount of interface such as lighthouses and sector lights. The mini or small unit is a cut down version intended for use with beacons that do not need the interface or capability of the larger unit.

The basic things monitored on both units are:

- Beacon on
- Voltage and current
- Flash character
- Daytime/night time
- Temperature
- Communication (monitored by web server)

Both units can provide on demand control over the cellular network from either the Internet browser or mobile phone. The on period is programmable. With on demand control the outstation will acknowledge the command by sending messages back to the phone.

Optional extras

- **GPS** for position information and providing a synchronising pulse. This allows geofencing alarms for buoy applications.
- **Accelerometer** for impact detection
- **Current transducer** (2 inputs per unit) allows for additional current monitoring where there is more than one current source to the beacon such as solar and battery. The multiple current measurements allow for energy balance monitoring.

Added capability of the large unit

- More inputs to monitor more items such as:
 - › Lampchanger position (lighthouse & sector light)
 - › Beacon rotation speed (lighthouse)
 - › Oscillating boundary operation (sector light)
 - › Night filter position (sector light)
 - › Security such as access sensors
- More outputs including high current outputs and logic capability for:
 - › Standby light control
 - › Standby power control
 - › On/Off control

Details of the Outstation input/output capability are detailed in the specification section.

Communication costs

The mini will operate on the GSM/GPRS and CDMA cellular networks. The large unit will also operate through the Orbcom satellite system.

Communication modems are included in the pricing of the unit but price varies depending on the modem type. The Mini unit comes with an internal cellular antenna. Cost of the large unit excludes an antenna.

To provide control on communication costs, the frequency of communication is programmed by the user. Data is stored in the outstation until transferred to the web server. Both the communication and data logging frequency is user programmable.



Use of the VegaWeb monitoring system incurs an annual cost per unit. This charge only applies to customers for the first 20 units. Any additional units above 20 units do not incur a system usage cost.

The cellular network account and associated costs are the responsibility of the user. Similarly, where satellite connection is used, the customer is responsible for the costs.

Alarm Operation

Alarms have 3 levels of notification including **maintenance warning** & **critical**. Maintenance and High/Low alarms are processed by the webserver each time a scheduled communication occurs. Critical alarms will cause the outstation to make an immediate call to the webserver. The webserver will notify the alarms by text message to cellular phones and by email to recipients set up by the user.

Alternative monitoring method using Mini unit

The Mini unit can operate by text messaging to a cellular phone. This eliminates the need for internet communication and the associated cost for data transfer and usage costs for the web server.

Web Browser interface

Access is obtained using login and password control. The user controls the allocation and issue of passwords. Once logged in, the user will see only their own data and no data from other Vega Web customers.

Each customer has their own configuration area and is able to set up and configure the system as if a software application was resident on their own computers.

The home page provides a status summary of any un-cleared alarms and any outstations that have failed to communicate. Site and equipment details are maintained within the site.

All data is shown in graphical form using a defined date range. Data is also available in tabular numeric format.

Alarm handling, including type, conditional alarms, levels and actions are programmable within the web server.

VEGAWEB NETWORK DIAGRAM

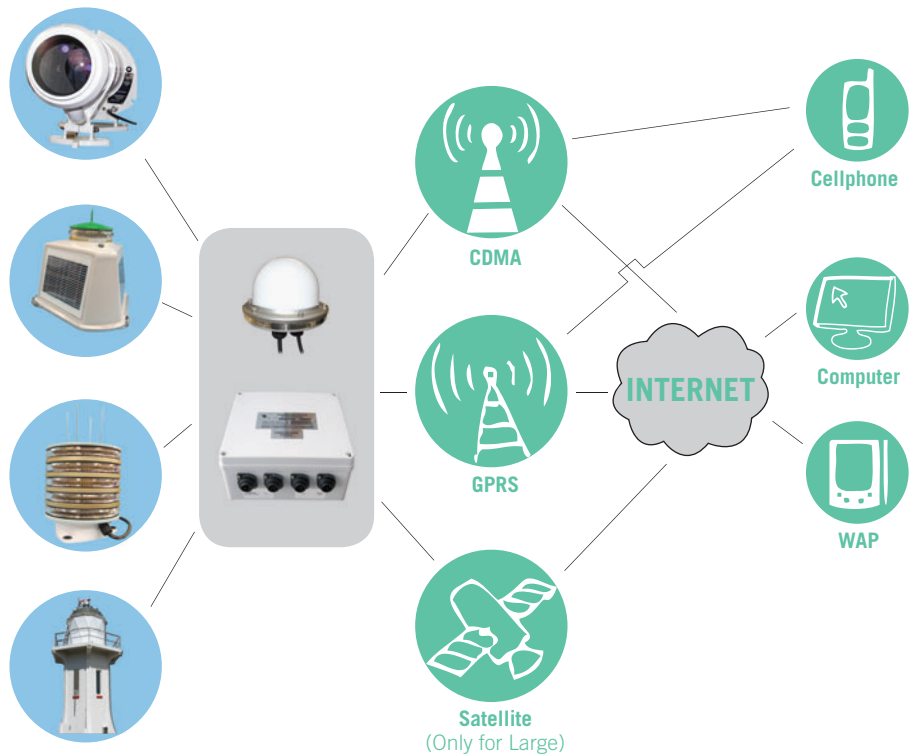

VEGAWEB USER INTERFACE

The screenshots show the VegaWeb user interface. The top screenshot displays the 'View site - Castlepoint' page, which includes site details, future events, and alarm configuration options. The bottom screenshot shows the 'View A2N - Cape Egmont K4088' page, featuring a table of A2N status and two line graphs: 'Current Out Average' and 'Battery Voltage'.

A2N	Current state	Event status	Last logged at
Castlepoint K3994	Critical	Processed	2007-06-19 13:03:00.0

Current Out Average
Last Value: 3.92

Battery Voltage
Last Value: 14.83

SPECIFICATIONS

Large outstation – Electrical

Power Requirement: Supply voltage 12VDC or 24VDC, Max voltage 39VDC, Charge current 250mA average (600mA peak) at 12VDC for 9 minutes, Normal current 17mA at 12VDC (not transmitting & no GPS) Current when transmitting 100mA. Additional current with GPS 20mA (on for 4 minutes every 20 mins - configurable)

Backup power: Super capacitor 100F @ 2.5VDC, Maintains power for 15 minutes

Digital inputs: 4 differential inputs, maximum voltage ± 40 VDC, low threshold 0.9VDC, high threshold 2.1VDC,

Rotation speed input: ± 5 to 30VDC

Lamp change input: ± 5 to 30VDC

Digital outputs: 4 open drain outputs, 60mA max sink current, max voltage ± 30 VDC(optional)

Synch pulse output: 2 outputs, positive and negative pulse

Optional Power outputs: 2 solid state 10A outputs, 100A inrush for 100ms

Analogue inputs: 2 inputs 0 to 5VDC accuracy ± 15 mV, 1 input 0 to 25VDC accuracy ± 60 mV

Current measurement: Maximum ± 10 A continuous, inrush 100A for 100mSec, range selectable 1 or 10A

Voltage measurement: 2 inputs, primary & secondary, max voltage 39VDC

Light sensor: VT300 LDR, 160kohms @10LUX nominal

Data: RS232 port for external device (AIS unit), selectable RS485 or RS232 port (A2N interface)

Internal sensors: Temperature, GPS position and time (optional), Accelerometer (optional)

Communications: Internal GPRS, CDMA or Satellite modem. Wavecom GPRS Q24Plus, Wavecom CDMA Q2438. Stellar Satellite DS100

Mechanical Specifications

Temperature: -20 to +60 degrees celcius

Enclosure: High impact PVC, sealed to IP56

Electrical connection: 4-PIN CPC with 1 meter cable provided

Aerial connection: SMA

Mini unit – Electrical

Power Requirement: Supply voltage 12VDC or 24VDC, Max voltage 39VDC, Charge current 250mA average at 12VDC for 9 minutes, Normal current 10mA at 12VDC (not transmitting). Current when transmitting 100mA session approx 2 mins. Additional current with optional GPS 20mA (on for 4 minutes every 20 mins - configurable)

Backup power: Super capacitor 100F @ 2.5VDC, (allows for alarm notification for 10mins from loss of power)

Digital inputs: 2 digital or analogue 0-30VDC, maximum voltage 50VDC, low threshold 0.9VDC, high threshold 2.1VDC - configerable.

Digital outputs: 1 open drain output, 60mA max sink current, max voltage ± 30 VDC

Synch pulse output: 1 output, positive and negative pulse, 10mA max sink current @ 12VDC supply, 30VDC max voltage (when GPS option fitted)

Power outputs: Nil

Analogue inputs: See digital inputs above

Current measurement: Two current inputs: ± 10 A & 0-10A. Maximum 5-36VDC high side measurement only, max 100A for 100ms

Voltage measurement: 0-30VDC, max +50VDC

Internal sensors: Light sensor, silicon light sensor (human eye response), temperature, accelerometer (optional) GPS position plus sync (optional)

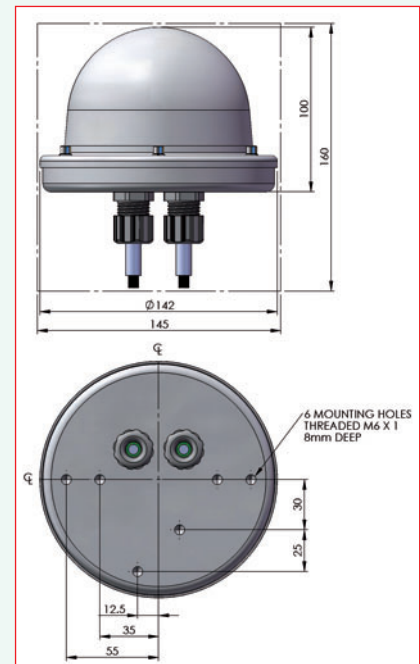

Data: RS232 port for AIS (on request)

Communications: Internal cellular modem, Wavecom GPRS Q24Plus or CDMA Q2438, internal antenna

Mechanical Specifications

Temperature: -20 to +60 degrees celcius

Enclosure: High impact acrylic/PVC, sealed to IP67

Electrical connection: 4 core & 12 core cable

Auxiliary current transducer

Used with large unit only. Current input 1 +/-25A, output voltage 0-5VDC; Current input 2 +/-25A, output voltage 0-5VDC; Zero current value of analogue output 2.5VDC, power requirement 2.2mA at 12VDC.

PARTS FOR ORDERING

Large outstation
Mini unit
Server access
Current transducer
Wiring harness for PEL & Rotating beacon
Whip antenna for large unit

VWEB-GPRS*
VWEBM-GPRS*
VWEB-SERV
VWEB-CURR
VWEB-WIREXX**
VWEB-ANT

*Replace with either CDMA or SAT for alternative modems

**Replace XX with 03, 06 (PEL lights) or 25 (rotating beacon)

For GPS option add GS to end of code. For accelerometer add AC to end of code.

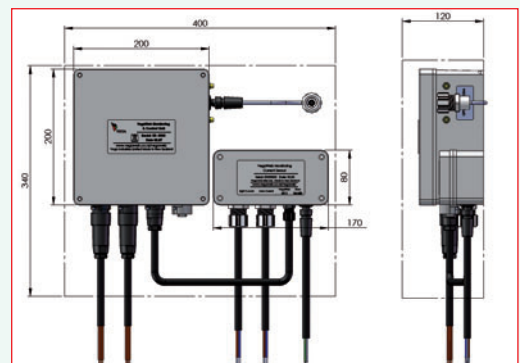

DISTRIBUTOR

Released on 5 November 2013

Vega Industries Ltd T: +64 4 238 0200 F: +64 4 237 4392 E: sales@vega.co.nz www.vega.co.nz

PO Box 50443, Porirua, Wellington 5240, New Zealand; 21 Heriot Drive, Porirua, Wellington 5022, New Zealand